

## LIFTMATE VVE 1000 SEMI ELECTRIC PALLET STACKERS

The **LiftMate VVE 1000** Semi Electric Pallet Stackers are ergonomically designed 1000kg capacity heavy duty stackers that come with a range of lift heights up to 3700mm.



WRAPOVER ADJUSTABLE FORKS



STRADDLE AND ADJUSTABLE FORGED FORKS ON ISO CARRIAGE



## FEATURES & BENEFITS

- Ergonomic design with tiller at waist height for easy maneuverability
- Electro-hydraulic raising and lowering of forks
- Standard lift heights up to 3700mm, special lift heights up to 4500mm
- Standard capacity: 1000kg, special capacities of 1200, 1500, 1800 and 2000kg also available
- Large wheels ensure good maneuverability
- Overload valve prevents damage through overloading
- Machines are easy to use in the tightest of spaces
- Pulling and pushing can be performed using the tiller or handles
- Very robust design and build
- Steer wheel fitted with brake
- Options include straddle legs, galvanized finish, adjustable forks, jibs, booms, platforms and other attachments

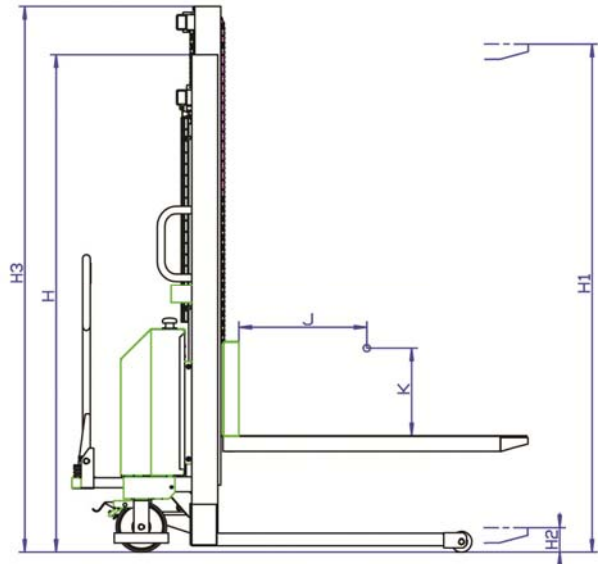
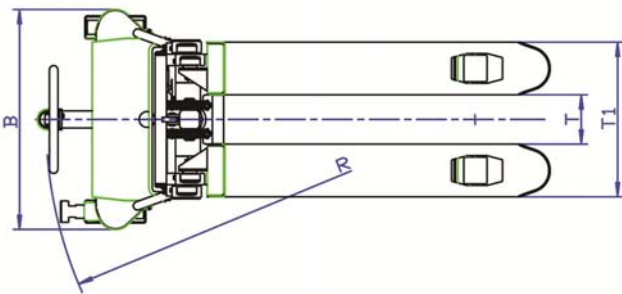

Model	Capacity	B mm	H mm	H <sub>1</sub> mm	H <sub>2</sub> mm	H <sub>3</sub> mm	L mm	L <sub>1</sub> mm	t mm	T <sub>1</sub> mm	R mm	Battery	Approx. Weight
VVE 1000/1120	1000	665	1585	1120	90	1585	1800	1150	173	545	1650	12V/125Ah	285
VVE 1000/1600	1000	665	1970	1600	90	2040	1800	1150	173	545	1650	12V/125Ah	310
VVE 1000/2000	1000	775	1470	2000	90	2425	1800	1150	173	545	1650	12V/170Ah	390
VVE 1000/2500	1000	775	1720	2500	90	2925	1800	1150	173	545	1650	12V/170Ah	420
VVE 1000/3000	1000	775	1970	3000	90	3425	1800	1150	173	545	1650	12V/170Ah	450
VVE 1000/3500	1000	775	2220	3500	90	3925	1800	1150	173	545	1650	12V/170Ah	480
VVE 1000/3700	1000	775	2320	3700	90	4125	1800	1150	173	545	1650	12V/170Ah	500